

Screw pumps – PX series

For hydraulic oils, lubricating oils

Admissible delivery pressure (continuous) = 30 bar at 2900 rpm



Main field of application:

Industrial purpose, low pressure range:
lubrication and cooling systems



Section and components

Inspection flange
(Not on PX025)

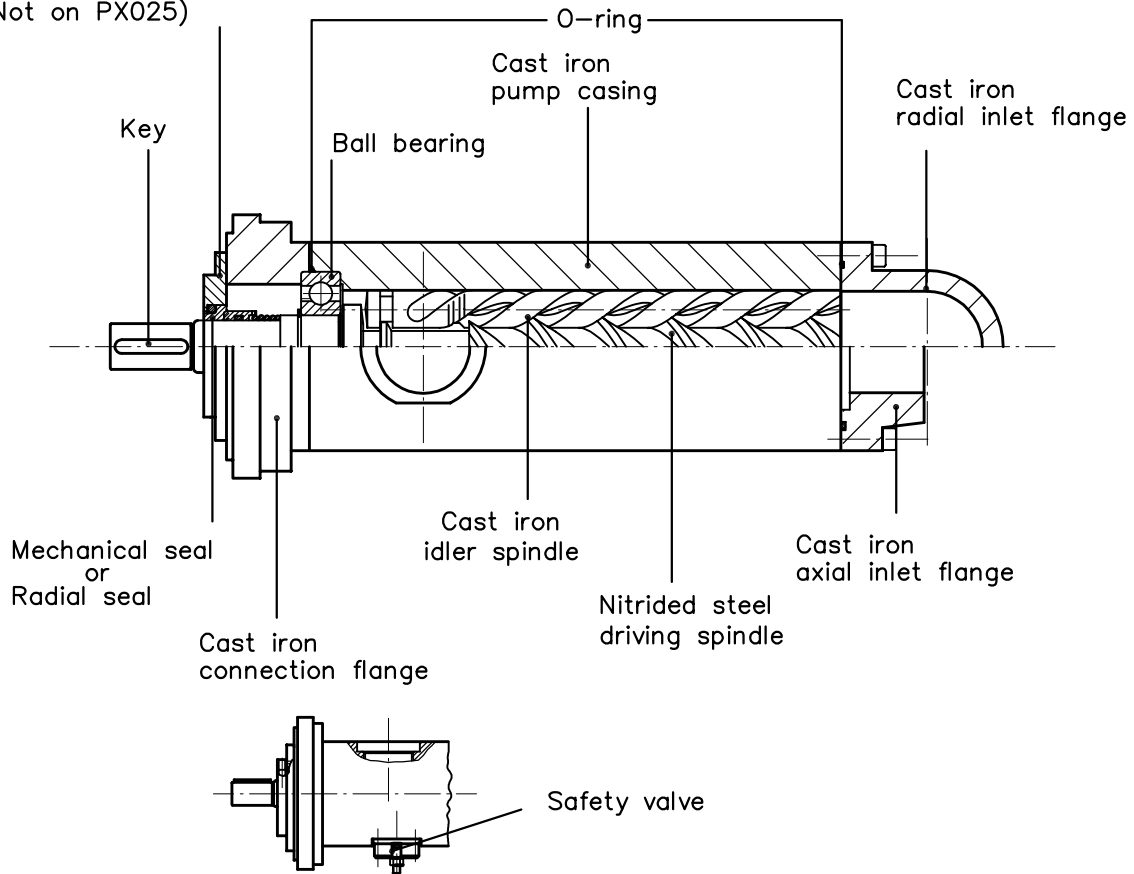

Functional characteristics standard version

Delivery flow	10 to 3000 l/min (2,6 to 800 USGPM)	
Admissible delivery pressure*	up to 30 bar (435 psi) continuous	
Admissible suction pressure	-0,5 to 10 bar (-7,3 to 145 psi)	For different values contact SEIM
Kinematic viscosity	10 to 400 cSt	For different values contact SEIM
Admissible temperature	0 to 120 °C (32 to 248 °F)	For different values contact SEIM
Driving speed	750 to 3600 rpm	
Average noise level	53 ÷ 75 dB(A) at 2900/1800 rpm according to pump dimension	
Recommended filtration	60 micron max, suction side (not abrasive contaminant) ISO4406 19 / 16 – NAS 10	
Direction of rotation	clockwise, as seen from the driving side	
* Standard valve setting	mod. A: 0 – 7 bar (0 – 102 psi)	mod. B: 7 – 16 bar (102 – 232 psi)

* Reduced pressure limits apply due to fluid viscosity and driving speed
Consult the performance charts for the individual pump size

For different functional characteristics, please contact our sales department

Screw pumps – PX series

For hydraulic oils, lubricating oils

Admissible delivery pressure (continuous) = 30 bar at 2900 rpm

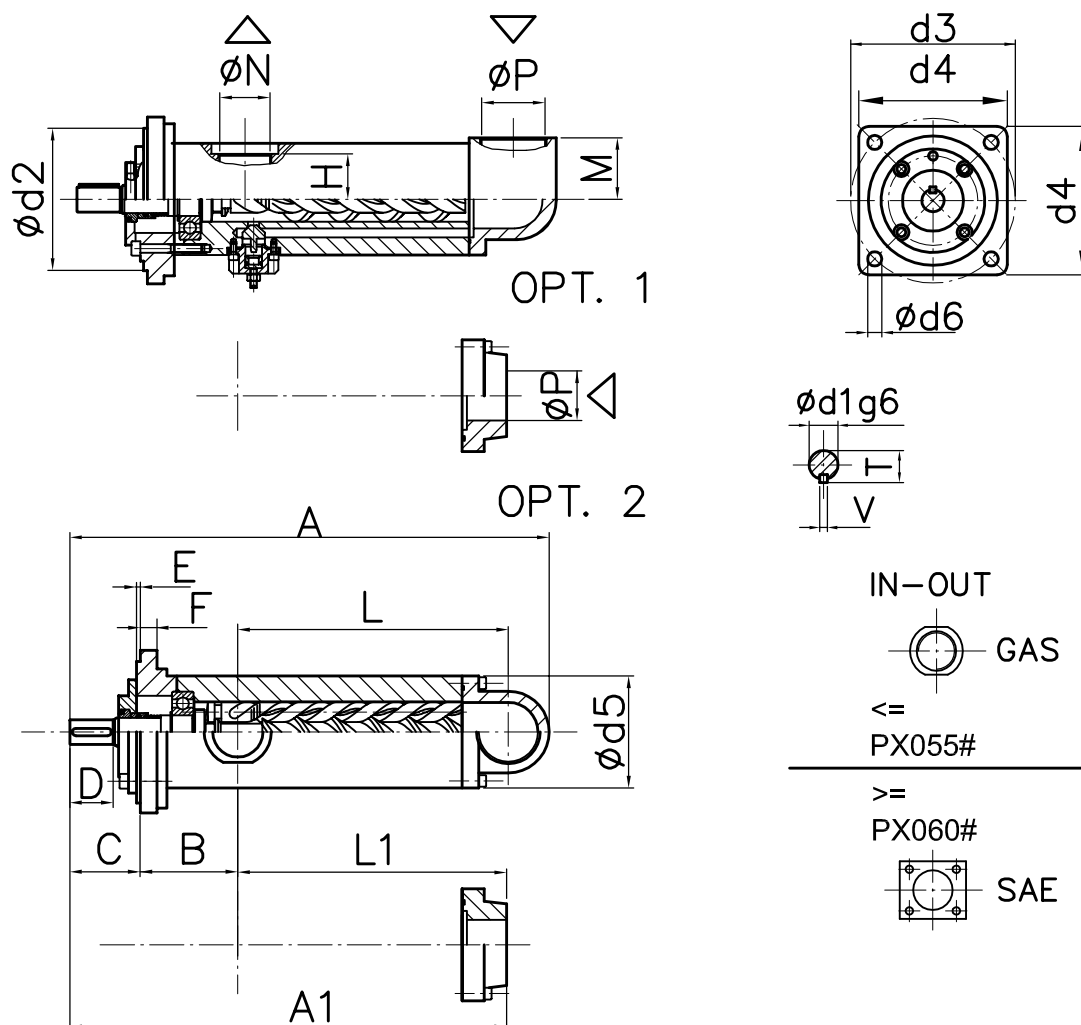

NF - STE - PX - GB 04-07 - 2

Inlet flange adjustable to 90° and 180

Dimensional chart (mm)

SIZE	A	A1	B	C	D	E	F	H	L	L1	M	N	P	T	V	d1	d2	d3	d4	d5	d6
PX025#6...	310	294	65	47,5	25	5	10	32,5	178	181	42	¾"	1"	16	5	14	100	125	150	80	11
PX032#4...	412	360	73	75	40	5	15	40,5	227	212	60	1½"	2"	21,5	6	19	125	160	145	100	13
PX040#4...	440	390	73	75	40	5	15	40,5	256	241	60	1½"	2"	21,5	6	19	125	160	145	100	13
PX045#4...	494	431,5	91,5	81	51	5	15	55,5	269	259	75,5	2"	2½"	35	10	32	125	160	145	135	13
PX055#4...	534	472	91,5	82	51	5	15	55,5	308	298	75,5	2"	2½"	35	10	32	125	160	145	135	13
PX060#4...	631	526,5	88	83,5	51	5	18	75	387	355	100	2½"	4"	35	10	32	160	200	195	170	18
PX072#4...	717	613	88	101	65	5	18	75	455	424	100	2½"	4"	35	10	32	160	200	195	170	18

SEIM srl
Via A. Volta 17
20090 Cusago (MI) ITALY
Tel. (+39) 02.90.39.21.1
Fax (+39) 02.90.39.21.41
e-mail: seim@seim.it

www.seim.it

SEIM reserves the right to introduce dimensional changes or variation to the products of this technical data

Screw pumps – PX series

For hydraulic oils, lubricating oils

Admissible delivery pressure (continuous) = 30 bar at 2900 rpm

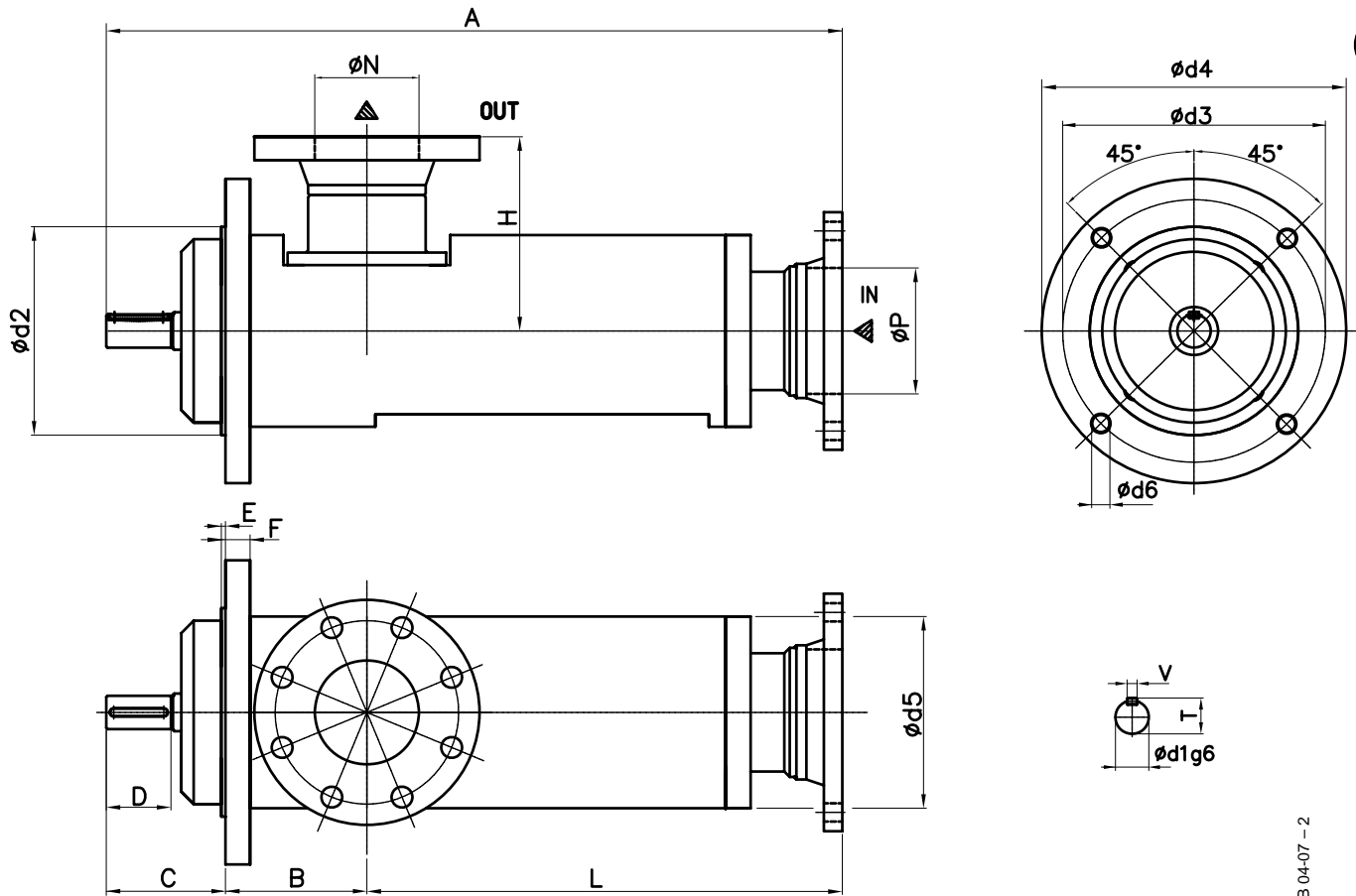

(x) no valve
Option / radial inlet - special

*Motor connection flange - body in aluminium, With valve

NF - STE - PX - GB 04-07 - 2

Dimensional chart (mm)

MODEL	A	B	C	D	E	F	H	L	N	P	T	V	d1	d2	d3	d4	d5	d6
* PX083#3..	785	194	90	80	5	30	95,5	406	4"	5"	48,5	14	45	250	315	365	180	26
x PX083#3..	696	154	128	80	5	30	77	414	4"	5"	43	12	40	200	250	292	210	22
x PX102#3...	883	170	143	80	5	30	79	570	DN125 PN40	DN150 PN16	43	12	40	250	315	365	260	22
x PX126#3...	944	185	143	80	6	30	83	620	DN150 PN40	DN150 PN16	43	12	40	250	315	365	260	22

SEIM srl
Via A. Volta 17
20090 Cusago (MI) ITALY
Tel. (+39) 02.90.39.21.1
Fax (+39) 02.90.39.21.41
e-mail: seim@seim.it

www.seim.it

SEIM reserves the right to introduce dimensional changes or variation to the products of this technical data